

**GENERAL DIMENSION DRAWING
OF FTT 16 SEREIS VERTICAL PUMP**

SERIES -16

MODEL	MOTOR HP	A	B - 3PH	B-1PH
FTT-16-2	3	371	285	320
FTT-16-3	4	406	325	-
FTT-16-4	5	441	335	-
FTT-16-5	7.5	476	370	-
FTT-16-6	10	522	380	-
FTT-16-7	10	557	380	-
FTT-16-8	12.5	592	410	-
FTT-16-9	12.5	627	410	-
FTT-16-10	15	697	510	-
FTT-16-11	15	732	510	-
FTT-16-12	20	767	510	-
FTT-16-13	20	802	510	-
FTT-16-14	20	873	510	-

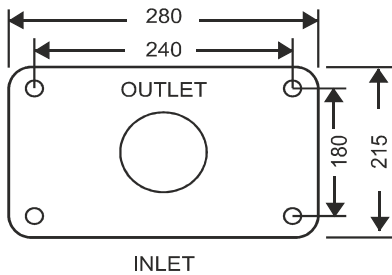
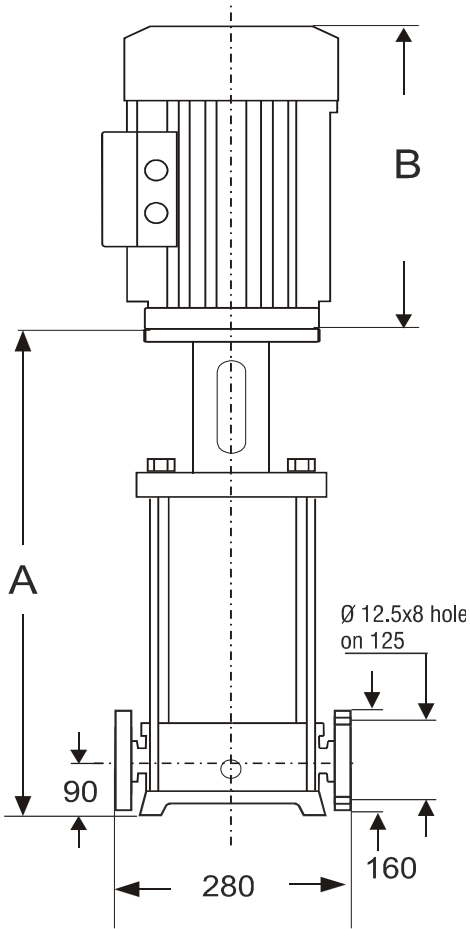

PUMP BASE

All dimensions are approximate and may be changed without any prior notice
All dimensions are in MM